

## Bourdon Tube Pressure Gauges with Switch Contacts Models MBSA, Stainless Steel Version



### Applications

- Control and regulation of industrial processes
- Monitoring of plant and switching of electric circuits
- For gaseous and liquid aggressive media that are not highly viscous or crystallising, also in aggressive ambience
- Process industries: chemical/petro-chemical, power stations, mining, on- and offshore, environmental technology, machine building and plant construction

### Special Features

- High reliability and long service life
- Up to 4 switch contacts per instrument
- Also available with liquid-filled case for high dynamic pressure loads and vibration
- Gauges with inductive contacts for use in hazardous areas with ATEX approval
- Gauges with electronic contacts for PLC applications
- Gauges in safety pattern version S3 (S)



**Pressure Gauge with Alarm Contact Model MBSA**

### Description

Wherever the process pressure has to be indicated locally, and, at the same time, circuits are to be made or broken, the model MBSA switchGAUGE can be used.

Switch contacts (electrical alarm contacts) make or break an electric control circuit dependent upon the position of the instrument pointer. The alarm contacts are adjustable over the full extent of the scale range (see DIN 16 085), and are mounted predominantly below the dial, though also partly on top of the dial. The instrument pointer (actual value pointer) moves freely across the entire scale range, independent of the setting.

The set pointer can be adjusted using a detachable adjustment key in the window.

Alarm contacts consisting of several contacts can also be set to a single setpoint. Contact actuation is made when the actual value pointer travels beyond or below the desired set value.

The pressure gauge is manufactured in accordance with EN 837-1 and fulfils all requirements of the relevant standards and regulations for the on-site display of the operating pressure of pressure vessels.

As switch contacts magnetic snap-action contacts, inductive contacts - for requirements to ATEX - or electronic contacts for triggering a PLC are available.

For further information on the different switch contacts please see data sheet EA801.

**Standard version****Nominal size in mm**

100, 160

**Accuracy class**

1.0

**Scale ranges**

0 ... 0.6 to 0 ... 1600 bar

or all other equivalent vacuum or combined pressure and vacuum ranges

**Pressure limitation**

Steady: full scale value

Fluctuating: 0.9 x full scale value

Short time: 1.3 x full scale value

**Operating temperature**

Ambient: -20 ... +60 °C without liquid filling and gauges with silicon oil filling

Medium: +200 °C maximum without liquid filling  
+100 °C maximum with liquid filling**Temperature effect**

When the temperature of the measuring system deviates from the reference temperature (+20 °C):

max. ±0.4 %/10 K of full scale value

**Process connection**

Stainless steel 316L,

lower mount (LM) or lower back mount (LBM)

G ½ B (male), 22 mm flats

**Pressure element**

Stainless steel 316L

&lt; 100 bar: C-type

≥ 100 bar: helical type

**Movement**

Stainless steel

**Dial**

Aluminium, white, black lettering

**Pointer**

Instrument pointer: aluminium, black

Desired value indicator: red

**Case**

Stainless steel

Model MBSA: with pressure relief in case back,  
scale ranges ≤ 0 ... 16 bar with compensating valve to vent case,**Window**

Laminated safety glass

**Bezel ring**

Cam ring (bayonet type), stainless steel

**Electrical connection**

Junction box

**Switch contacts****Magnetic snap-action contact model D21**

- No control unit and no extra power supply required
- Direct switching up to 230 V
- Up to 4 switch contacts per measuring instrument
- Suitable for Ex zone 22 (3 D)

**Inductive contact model D31**

- Long service life due to non-contact sensor
- Additional control unit required
- With corresponding control unit suitable for use in Zone 1 / 21 (2 GD) hazardous areas
- Low reaction on the display accuracy
- Fail-safe switching at high switching rates
- Insensitive to corrosion
- Up to 3 switch contacts per measuring instrument

**Contact function**

The contact function of the switch is indicated by function index 1, 2 or 3.

Model DXX.1: Contact makes (clockwise rotary motion of the pointer)

Model DXX.2: Contact breaks (clockwise rotary motion of the pointer)

Model DXX.3: Change over; one contact breaks and one contact makes simultaneously when pointer reaches set point

**For further information please see data sheet EA801, Electrical Switch Contacts****Options**

- Other process connection
- Liquid filling
- Inductive contacts also in safety version
- Dual scale
- Panel mounting flange, polished stainless steel
- Surface mounting flange, stainless steel
- Surface mounting lugs on case, stainless steel
- SIL2 approval

## SwitchGAUGE Model MSBA-10, NS 100

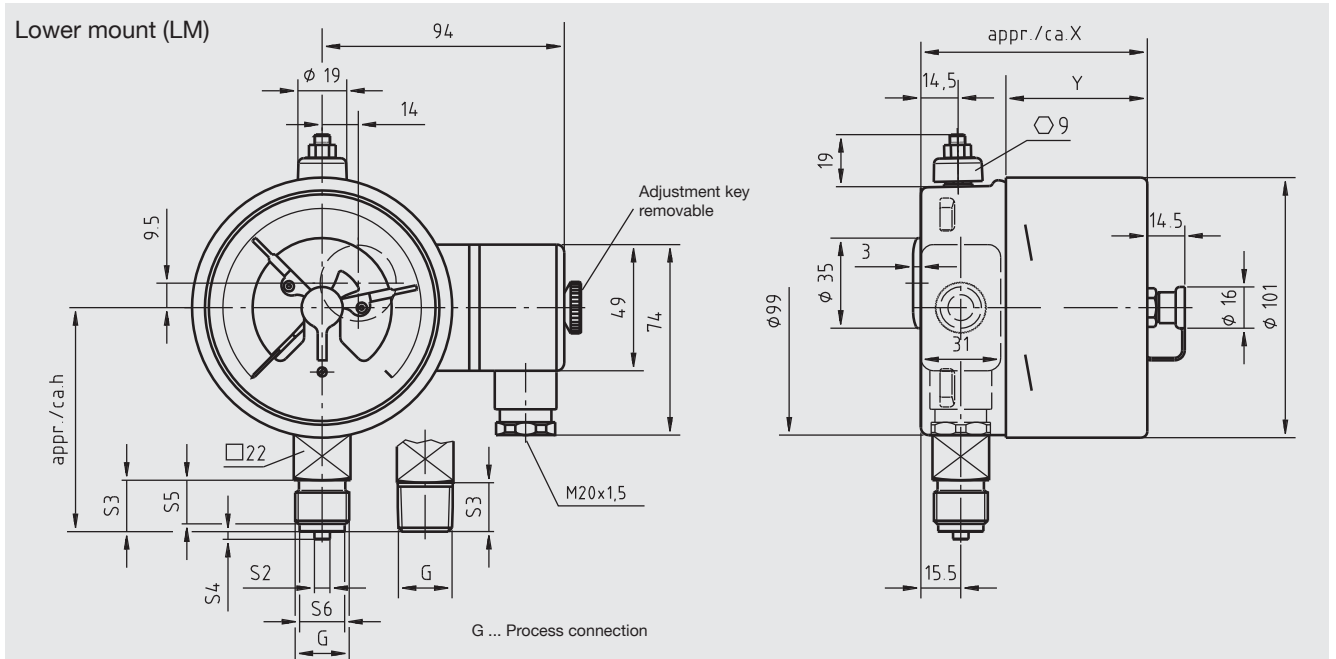

Type of contact	Dimensions in mm	
	X	Y
Single or double contact	88	55
Double contact (SPDT)	113	80

Process connection	Dimensions in mm					
	h ± 1	S2	S3	S4	S5	S6
G 1/2 B	87	6	20	3	17	17.5
G 1/4 B	80	5	13	2	11	9.5
1/2 NPT	86	-	19	-	-	-

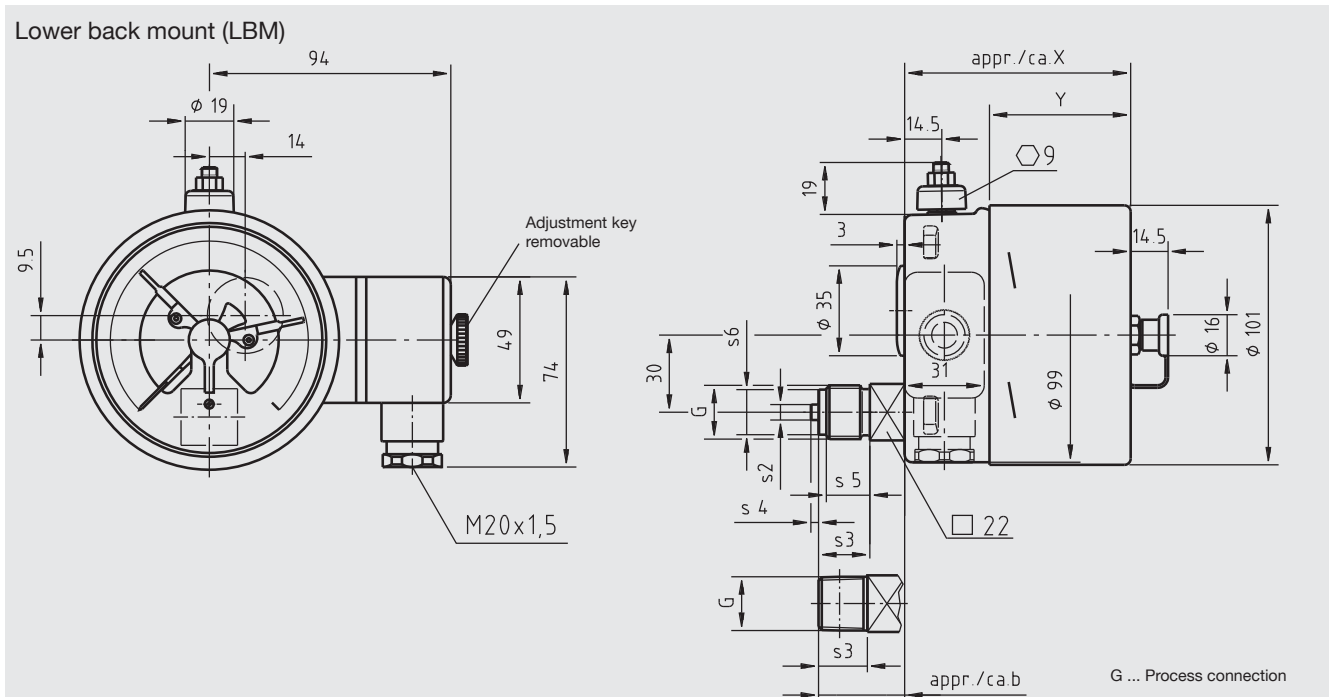

Type of contact	Dimensions in mm	
	X	Y
Single or double contact	88	55
Double contact (SPDT)	113	80

Process connection	Dimensions in mm					
	b	S2	S3	S4	S5	S6
G 1/2 B	33.5	6	20	3	17	17.5
G 1/4 B	26.5	5	13	2	11	9.5
1/2 NPT	32.5	-	19	-	-	-

## SwitchGAUGE Model MBSA-10, According S3, NS 100

### Lower mount (LM)

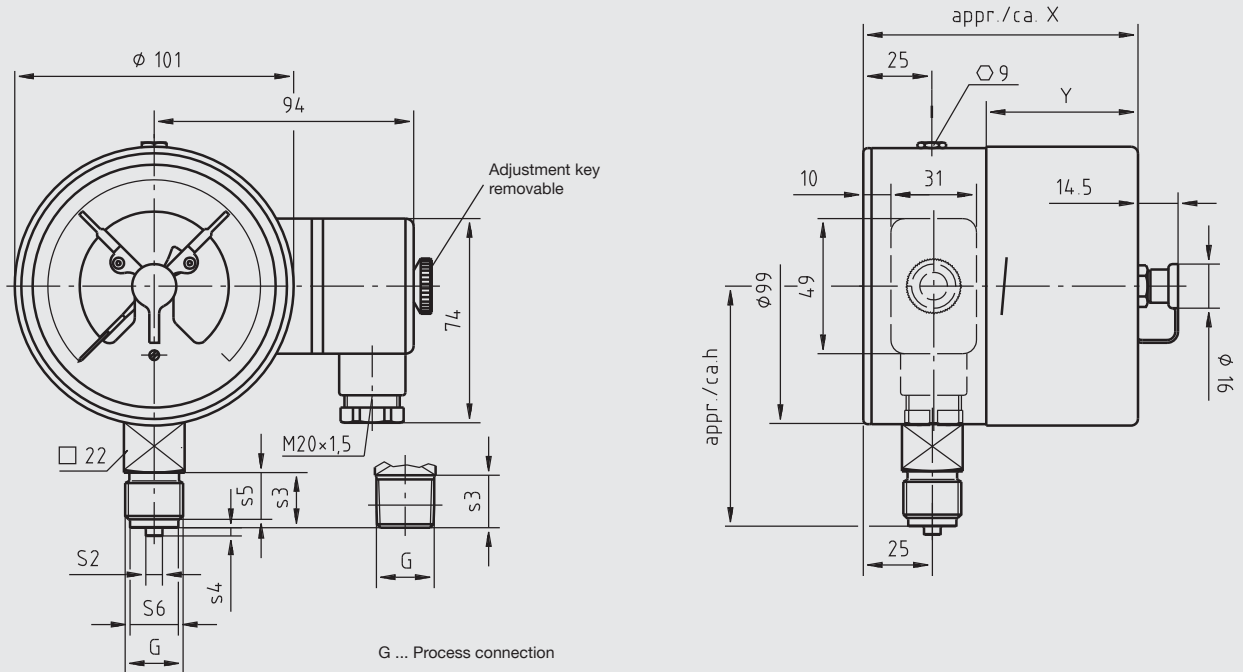

Type of contact	Maße in mm	
	X	Y
Single or double contact	97	55
Double contact (SPDT)	122	80

Process connection	Dimensions in mm					
	h ± 1	S2	S3	S4	S5	S6
G ½ B	87	6	20	3	17	17.5
G ¼ B	80	5	13	2	11	9.5
½ NPT	86	-	19	-	-	-

### Lower back mount (LBM)

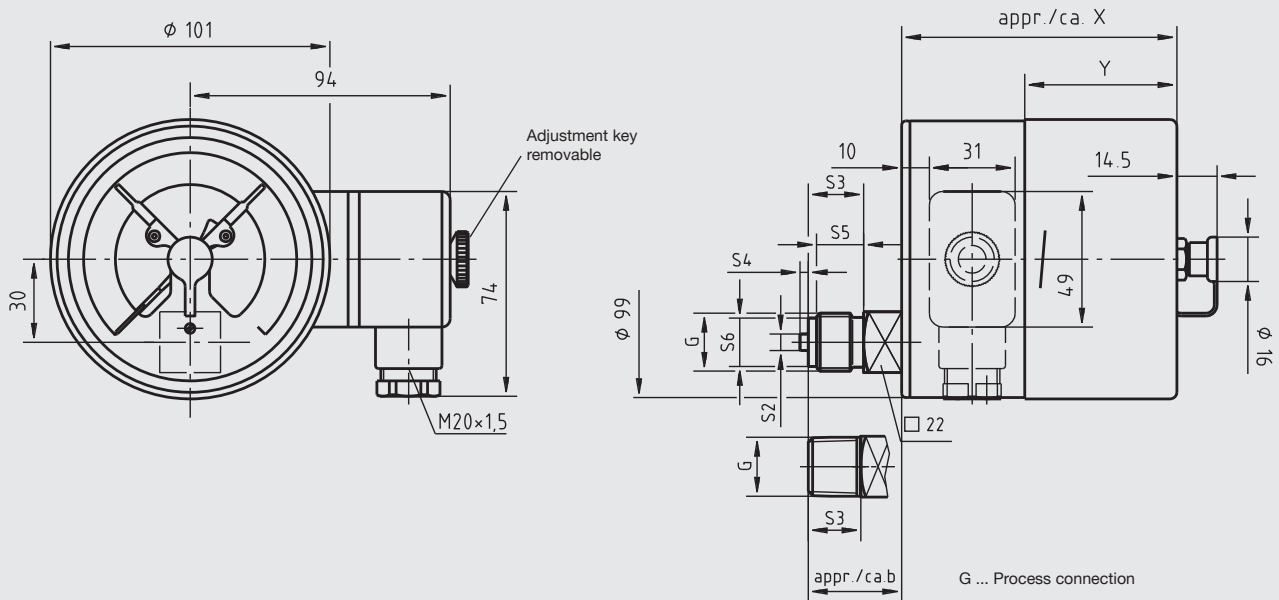

Type of contact	Dimensions in mm	
	X	Y
Single or double contact	97	55
Double contact (SPDT)	122	80

Process connection	Dimensions in mm					
	b	S2	S3	S4	S5	S6
G ½ B	33.5	6	20	3	17	17.5
G ¼ B	26.5	5	13	2	11	9.5
½ NPT	32.5	-	19	-	-	-

## Lower mount (LM)

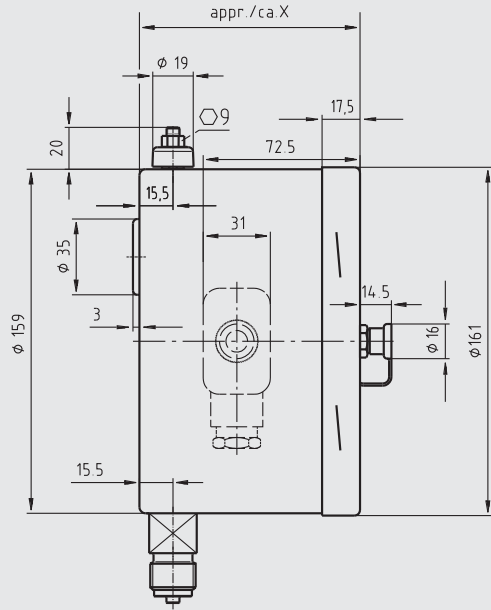
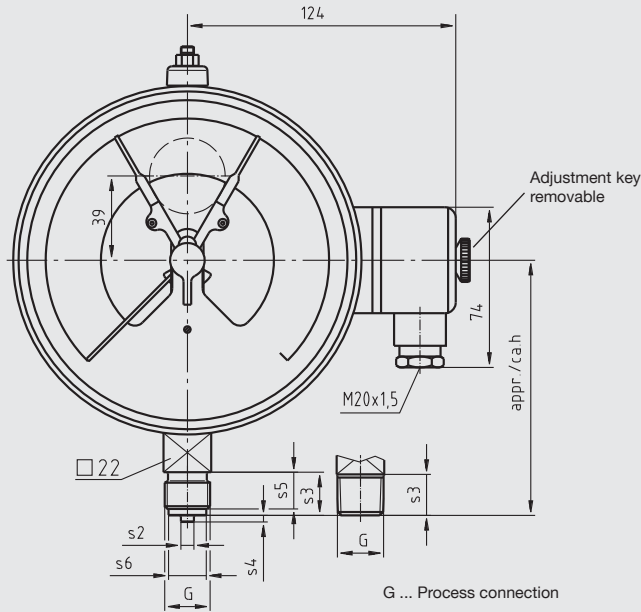

Type of contact	Dimensions X in mm
Single, double or triple contact	102 <sup>1)</sup>
Double contact (SPDT), quadruple contact	116 <sup>1)</sup>

Process connection	Dimensions in mm	h ± 1	S2	S3	S4	S5	S6
G ½ B		118	6	20	3	17	17.5
G ¼ B		111	5	13	2	11	9.5
½ NPT		117	-	19	-	-	-

## Lower back mount (LBM)

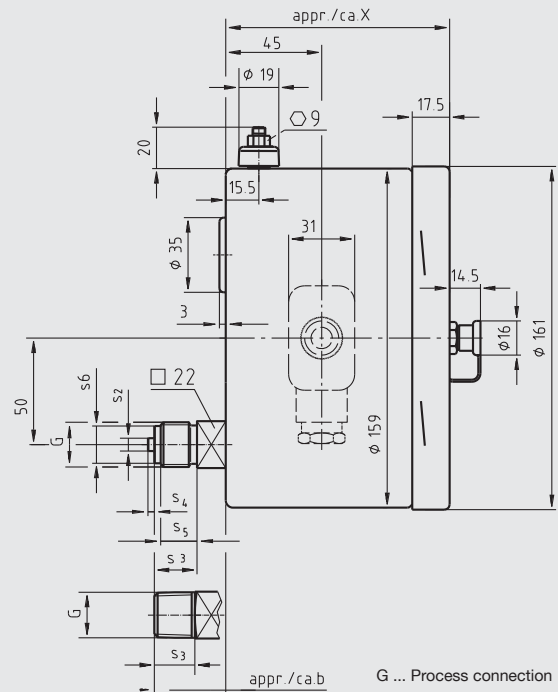
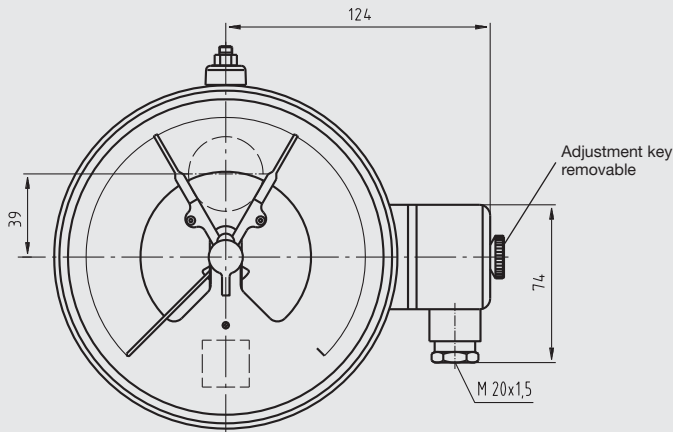

Type of contact	Dimensions X in mm
Single, double or triple contact	105
Quadruple contact	119

Process connection	Dimensions in mm	b	S2	S3	S4	S5	S6
G ½ B		33.5	6	20	3	17	17.5
G ¼ B		26.5	5	13	2	11	9.5
½ NPT		32.5	-	19	-	-	-

## switchGAUGE Model MBSA-16, According S3, NS 160

Lower mount (LM)

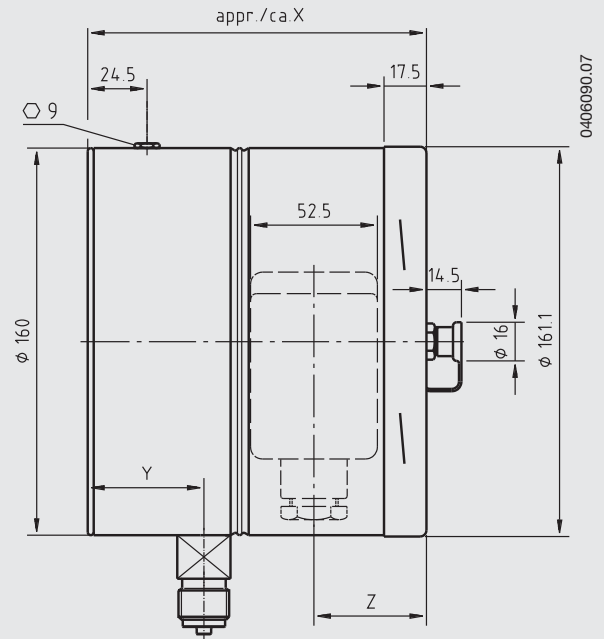
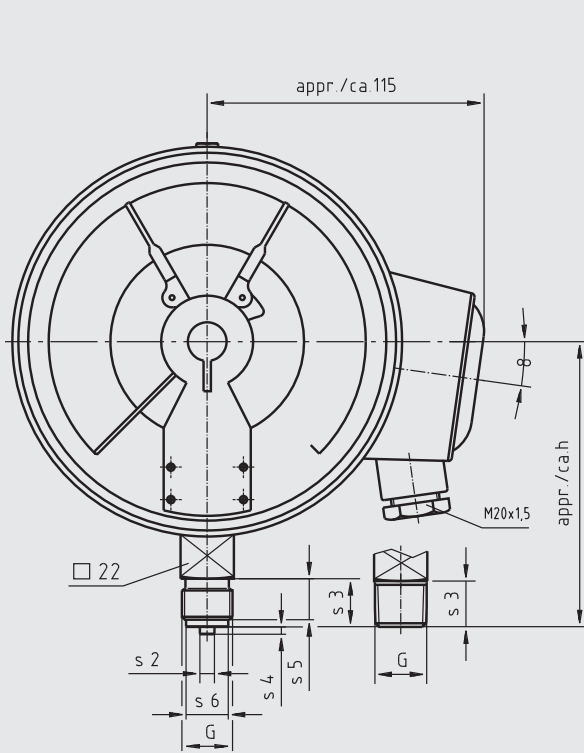

Type of contact	Dimensions in mm		
	X	Y	Z
Single or double contact	141	30.5	48
Triple contact	153.5	30.5	60.5

Process connection	Dimensions in mm					
	h ± 1	S2	S3	S4	S5	S6
G 1/2 B	118	6	20	3	17	17.5
1/2 NPT	117	-	19	-	-	-
M20 x 1.5	118	6	20	3	17	17.5